



## BD 202 HL



**BD 202 HL**

**AUSA**

www.ausa.com

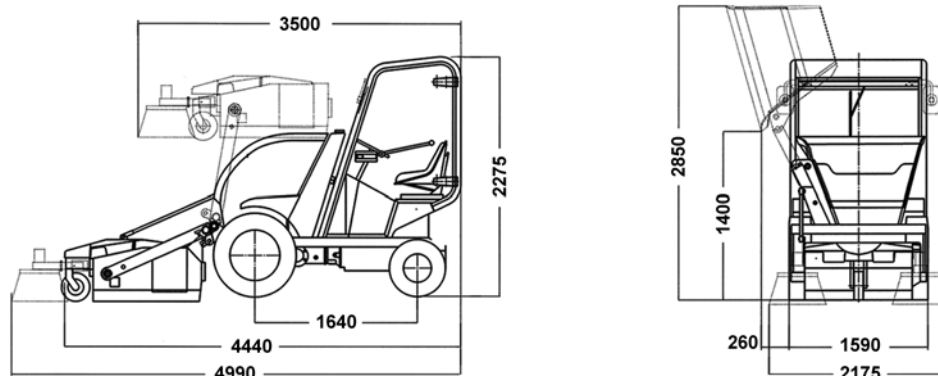

**TECHNICAL SPECIFICATIONS**

**BD 202 HL**

Hopper capacity (l)		900
Sweeper attachment capacity (l)		245
Elevation and unloading of the sweeper attachment		Hidraulical
Hopper unloading height (mm)		1500
Engine	Diesel	Kubota V1505
	Power s/DIN 6270B (kW/CV)	23.55 / 32.2 (2600rpm)
	Power s/DIN 70020 (kW/CV)	25.6 / 34.8 (2600 rpm)
	Nº cylinders	4
	Coolant	Liquid
Traction		4x4 Permanent Compen System
Transmission		2-Speed Hidrostatic ratios. Electrical gear inverter
Ignition		Electrical
Speed max. (km/h)		20
Sweep width (mm)		from 1720 to 2630
Desplazamiento lateral (mm)		400
Recomended sweep speed (km/h)		5
Central brush width (mm)		1200
Central brush diameter (mm)		450
Side brush diameter (mm)		850
Unloaded weight (with full tanks) (Kg)		2300
Maximum slope	Under full load	42%
	Sweeping	20%
Tyres	Front	10.0 / 80 - 12" TL (10PR)
	Rear	10.0 / 80 - 12" TL (10PR)
Steering		Hidraulical. Working Service 80 bar
External turning circle		4180
Tank capacity	Fuel (l)	40
	Hydraulic oil (l)	40
	Water supply for sprinkling (l)	350
Water pump		Electric of 12.5 l/min
Total sprinkling widht (mm)		2500
Hand brake		Sealed multi-discs on oil bath
Parking brake		Sealed multi-discs on oil bath
Hydraulic circuit		Double gear pump. Delivery 8cc for steering and 12cc for services. Service pressure 150 bar

**STANDARD EQUIPMENT**

- Ergonomic seat
- Rotating beacon
- Back-up alarm
- Seat belt
- Anti vandal System
- ROPS / FOPS protective roof
- Windscreen with wiper
- Additional passenger seat
- Approved lighting equipment
- Water flow control

**OPTIONAL EQUIPMENT**

- Self-loading bucket, capacity 130l, easily interchangeable with the sweeping equipment
- Closed cabin with heater
- Snow blade, operating width 2000mm with safety system against obstacles
- Tilting hydraulically on both sides +/- 30°
- Automatic cover on waste cargo box, by means of an hydraulic cylinder controlled with the joystic. Safety system against shocks, opening on cargo box with transparent plastic to control the level or waste, managing the collecting and transporting of waste on more ecological and efficient manner specially when picking up leaves
- High pressure water pump, maximum service pressure 150 bar, with hose reel, hose lenght 15m
- Special compartment for cleaning accessories as blowers, rakes, broom, etc.
- Air conditioning
- Stereo radio cd/mp3
- Equipment for low pressure watering