



TECHNICAL DATA

GENERAL		D151AEG
Unloading system	-	Rotating
Load capacity	Kg	1500
Chassis	-	Articulated
Water hopper capacity	l	520
Level hopper capacity	l	626
Heaped hopper capacity	l	900
Empty weight *	Kg	1565
Transmission	-	Electric
ENGINE		
Peak/Nominal power	kW	17,3 / 7,6
Peak torque	N.m	130
Emissions	-	Zero emissions
DRIVING		
Max. speed	km/h	15
Maximum gradient	%	35
External turning radius	mm	3390
Traction	-	4x4
Tyres	-	10.0/75-15.3
HYDRAULIC SYSTEM		
Hydraulic circuit	-	12cc. Gear pump
Flow rate	l/min	18
Working pressure	bar	170
Tank capacity	l	24,5
BRAKES		
Service	-	Sealed. Hydraulic drive
Parking	-	Negative brake and electro-hydraulic release
BATTERY		
Battery type	-	Lithium-Ion Battery (NCM)
Gross capacity	kWh	9,3
System voltage	V	48
Autonomy ***	-	One intense shift
CHARGE		
Charger	-	Integrated
Charging time 20-80% **	-	2h (@230V)
Charging time 20-80% (external fast charger) **	-	1h 24min (@415V)
Charging cable plug type	-	16A 110V (yellow); 16A 230V (blue); 16A 415V (red)

* It may change due to optional equipment. ** Subject to environmental conditions and to the kind and power of charging station. *** Subject to environmental conditions and the kind of use. For temperatures under 0°C it is recommended to fit the Long Range pack.

DIMENSIONS

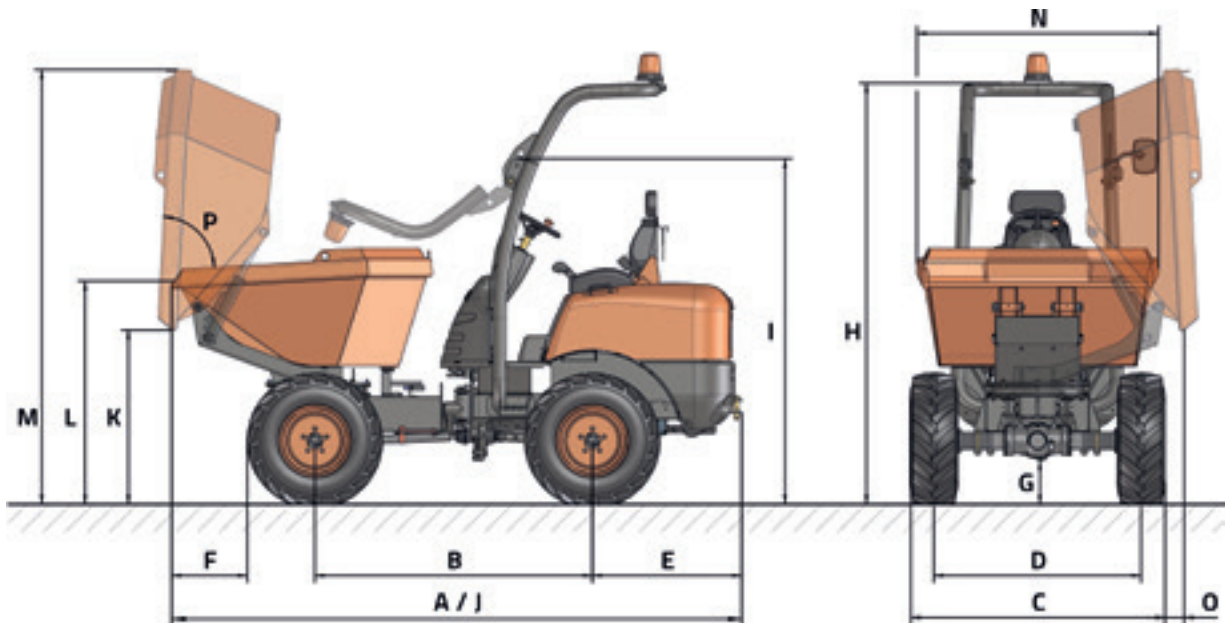

DIMENSIONS (mm)		D151AEG
A		3360
B		1650
C		1480
D		1195
E		885
F		460
G		250
H		2600
I		1730
J		3235
K		1000
L		1290
M		2500
N		1400
O		135
DIMENSIONS (°)		
P		83



www.ausa.com

Products are subject to modifications without prior notice. Images throughout the spec sheet may refer to non-standard machines or non-available configurations depending on models.

AUSA's logo and corporate identity are property of the Company, they cannot be used without authorization.