

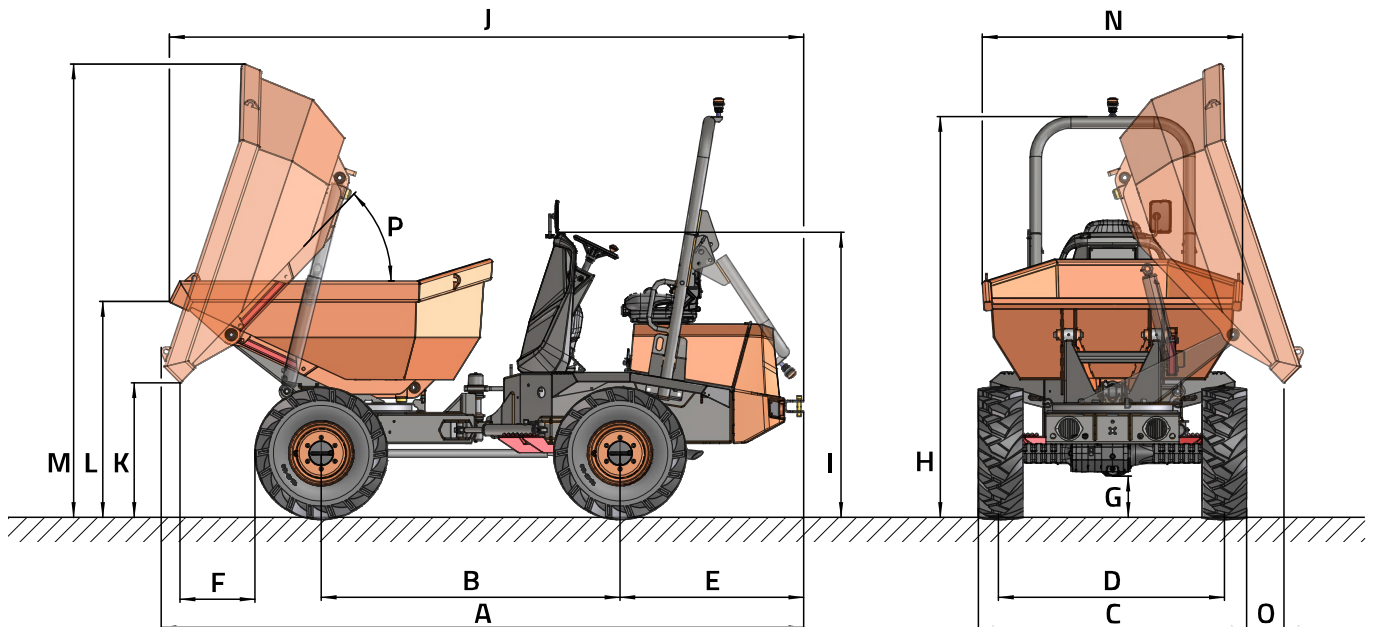

TECHNICAL DATA

GENERAL		D 201 AHG
Unloading system	-	Rotating
Load capacity	lb	4,400
Chassis	-	Articulated and oscillating
Water hopper capacity	cu yd	0.91
Level hopper capacity	cu yd	1.42
Heaped hopper capacity	cu yd	1.75
Empty weight	lb	4,592
Transmission	-	Hydrostatic
ENGINE		
Brand	-	KUBOTA
Model	-	V1505-E4B
Power	hp	24.8
Operating speed	rpm	2,300
Torque	N·m@rpm	92.6@1,700
No. of cylinders	-	3
Emissions	-	Stage V - EPA Tier4
Injection	-	Mechanical pump
Noise	dB(A)	101
DRIVING		
Max. speed	mph	12.4
Maximum gradient	%	50
External turning radius	in	146
Traction	-	4x4
Tyres	-	10.0/75-15.3"
HYDRAULIC SYSTEM		
Hydraulic circuit	-	0.73 cu in gear pump
Flow rate	gal/min	6.6
Working pressure	psi	2,538
TANK CAPACITY		
Fuel	gal	9.9
Hydraulic system	gal	9.8
BRAKES		
Service	-	Hydrostatic, retention
Parking	-	Negative, integrated in the transfer box

DIMENSIONS



DIMENSIONS (in)	D201AHG
A	157.3
B	74
C	59
D	48.6
E	47.2
F	18.9
G	9.4
H	100.8
I	71
J	157.3
K	36.8
L	51.4
M	114.6
N	58.3
O	10.2
DIMENSIONS (°)	
P	49



www.ausa.com

Products are subject to modifications without prior notice. Images throughout the spec sheet may refer to non-standard machines or non-available configurations depending on models.

AUSA's logo and corporate identity are property of the Company, they cannot be used without authorization.